

REAR HANDLEBAR AND LASER LIGHT

INSTALLATION INSTRUCTIONS FOR GALLANT™ LONGARM MACHINE

KIT CONTENTS

- (1) Rear Handlebar (QM29421)
- (1) Laser Light Assembly (QM10290)
Includes laser pin, laser light, and nylon mounting bracket
- (1) 3mm Hex Wrench (QM40406)
- (3) M5X12 Screw-SKB ZN (QM12017)

INSTALLING THE REAR HANDLEBAR

NOTE: Turn off and unplug the machine before installation.

1. Loosen the two screws from the rear handlebar connection cover and remove the plastic cover. Do not remove the screws.
 - **IMPORTANT:** There is a connector plugged into the back of the circuit board. If the board is loosened too much or pulled out, ensure the connector is fully plugged into the back of the circuit board before proceeding.
2. Retighten the two screws into the circuit board.
3. Locate the three M5X12 SKB ZN hex screws for the rear handlebar and the 3mm hex wrench.
4. Align the three holes in the handlebar with the holes on the back of the machine.
5. Slide the screws into the holes until they stop. Use the 3mm hex wrench to firmly tighten the bolts and securely fasten the handlebar to the back of the machine.
6. The contacts on the back of the handlebar will contact the circuit board, so no cable is needed to connect the rear handlebar to the machine.

✍ **NOTE:** After installing the rear handlebar, plug in the power cord and test by turning on the machine using the on/off switch. The buttons will function like those on the front handlebar.

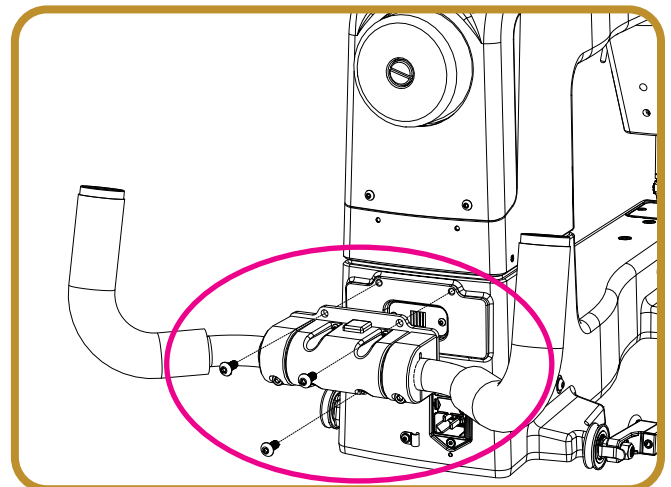
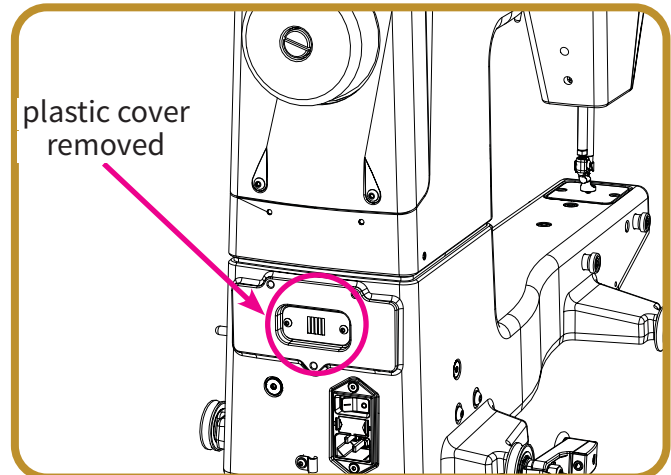
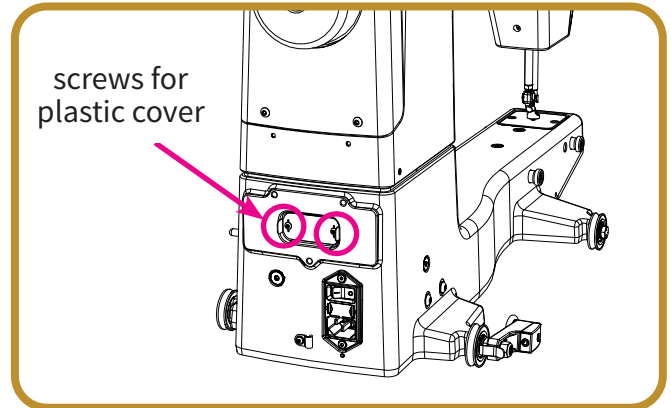

Machine and Rear Handlebar connections shown.

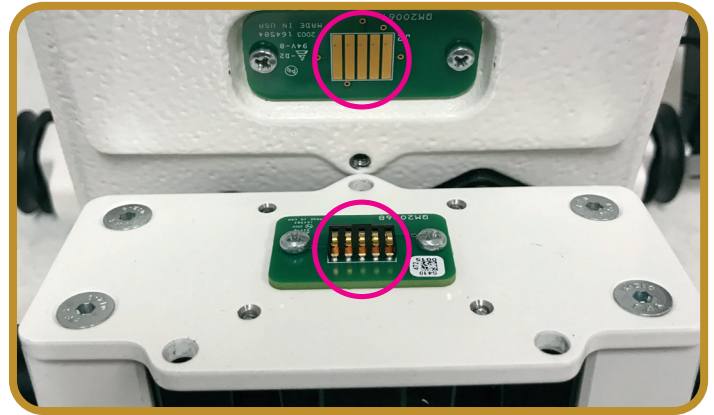

CONNECTING THE LASER

1. Remove the nut and washer from the laser pin. Screw the nut all the way onto the laser pin. Place the washer on the end and screw the laser pin into the threaded hole found near the rear wheel (see diagram). The washer will go against the machine to protect the paint finish.
2. While holding the laser pin firmly, tighten the nut with the 8mm wrench (provided).
3. Slide the laser and nylon mounting bracket onto the laser pin as shown.
4. Connect the 9 pin laser cable to the connector on the side of the machine.
5. Focus the laser by turning the threaded housing surrounding the lens clockwise or counterclockwise. The laser image can be adjusted to project a bigger or smaller dot, or focal size. The direction of rotation needed is determined by the distance of the laser from the pantograph surface. Experiment by rotating the threaded end to achieve your desired focal size.

