



BERNINA Q 24 | Q 20

Frame Mounting Manual



Edition notice

Text, Setting and Layout

BERNINA International AG

Photos

Patrice Heilmann, Winterthur

BERNINA International AG, Steckborn

Order number

2019-04 en 0365655.10A.04

Copyright

2018 BERNINA International AG

All rights reserved: For technical reasons and for the purpose of product improvements, changes concerning the features of the machine can be made at any time and without advance notice. The supplied accessory can vary depending on the country of delivery.



Table of Contents

IMPORTANT SAFETY INSTRUCTIONS	3	2.12 Machine preparation	38
1 My BERNINA	5	Overview	38
1.1 Further information	5	Getting the machine ready	41
1.2 Content of these instructions	5	Attaching the V-wheel units	41
Explanation of symbols	5	Attaching the front stand profile	42
1.3 Overview of the quilting frame	6	Attaching the rear stand profile	44
1.4 Overview of delivery	7	Positioning the machine on the carriage	46
1.5 Overview of large parts	7	Attaching safety brackets	47
1.6 Overview of small parts	8	Fitting rail covers	49
2 Quilting frame assembly	12	2.13 Take-up rail and dead bar attachment	50
2.1 Unpacking and checking the delivery	12	Attaching the Take-up rail	50
2.2 Recurring steps	12	Attaching the handwheel to the take-up rail	52
Fitting the slot nuts	12	Attaching the dead bar	53
Tightening the socket screws	13	2.14 Leader, side clamp, and storage tray attachment	55
2.3 Sequence of assembly steps	13	General notes on attaching the leaders	55
2.4 Working height adjustment	13	Attaching the Back leader	55
2.5 Base frame assembly	15	Attaching the Take-up leader	56
Overview components	15	Attaching the Top leader	57
Attaching adjustable levelling feet	16	Attaching the side clamps	58
Attaching the lower cross bar	16	Attaching the storage trays	59
Attaching the back bar	18	2.15 Front handle attachment	60
Attaching the front bar	21	Attaching the front handle unit	60
2.6 Rail support assembly	23	Adjusting the width of the handles	60
Attaching rail supports	23	Adjusting the handles	61
Adapting the rail support for BERNINA Q 20	24	3 Disposal	62
2.7 Tabletop positioning	25	3.1 Quilting frame disposal	62
Attaching tabletop brackets	25	4 Specifications	63
Positioning tabletops	25	5 Appendix	64
2.8 Quilting frame levelling	26	5.1 Differing information for the "Large" quilting frame	64
2.9 Track assembly	27	5.2 Differing information for the "Small" quilting frame	64
Attaching the rear track	27	Index	66
Attaching the front track	29		
2.10 Top and backing rail assembly	31		
Assembling the top rail	32		
Assembling the backing rail	33		
2.11 Carriage and park position magnet alignment	35		



IMPORTANT SAFETY INSTRUCTIONS

Please observe the following general safety instructions when assembling the quilting frame. Before using the quilting frame, also read the operating instructions for the machine from the BERNINA Q Series carefully.

WARNING

To protect persons from injuries:

- The packaging of the quilting frame and the machine is large and heavy. The packaging should therefore always be carried by at least two adults together.
- Position the packaging and individual parts so that they cannot fall over.
- Setting up the quilting frame requires at least two adults.
- During assembly of the individual and small parts, ensure that the parts are kept out of the reach of small children (risk of suffocation).
- During assembly, ensure that your fingers do not get trapped or caught.
- Only use the quilting frame for the purpose described in these assembly instructions.
- Do not use the quilting frame as a toy.
- The quilting frame can be assembled by children over the age of 8, as well as by persons with reduced physical, sensory, or mental capacities or with a lack of experience and knowledge, as long as they are supervised or have been made aware of the potential hazards.
- Only use accessories recommended by the manufacturer.
- Do not insert any objects into the openings on the quilting frame.
- Keep fingers away from all moving parts. Special caution is required in the area of the take-up rail, top rail and backing rail, as well as the carriage.

Availability of the instruction manual

The assembly instructions are part of the quilting frame.

- Store the assembly instructions for the quilting frame in a suitable location near the quilting frame and keep them available to consult.
- If the quilting frame is passed on to third parties, always include the assembly instructions with the quilting frame.



Proper use

The quilt frame serves as a support for the machines in the Q series and as a workplace for long arm quilting. Any other use is not considered proper. BERNINA assumes no liability for consequences resulting from improper use.



1 My BERNINA

1.1 Further information

You can find the latest version of your assembly instructions as well as a lot more information about quilting on our website at <http://www.bernina.com>

1.2 Content of these instructions

These assembly instructions describe assembly of the "Classic" quilting frame. With certain differences, the instructions also apply to assembly of the "Large" and "Small" quilting frames. The differences primarily concern the number of certain parts. You can find information on these differences in the following section:

- Differing information for the "Large" quilting frame (see page 64)
- Differing information for the "Small" quilting frame (see page 64)

Explanation of symbols



Labels a high-risk hazard which can lead to serious injuries or potentially even death if not avoided.



Labels a medium-risk hazard which can lead to serious injuries if not avoided.



Labels a low-risk hazard which can lead to minor or moderate injuries if not avoided.

NOTICE

Labels a hazard which can lead to material damage if not avoided.



Tips from BERNINA **quilt experts** can be found next to this symbol.

Example images are used in these operating instructions for the purposes of illustration. The machines shown in the images and the accessories shown therefore do not always match the actual items included with your machine.

1.3 Overview of the quilting frame

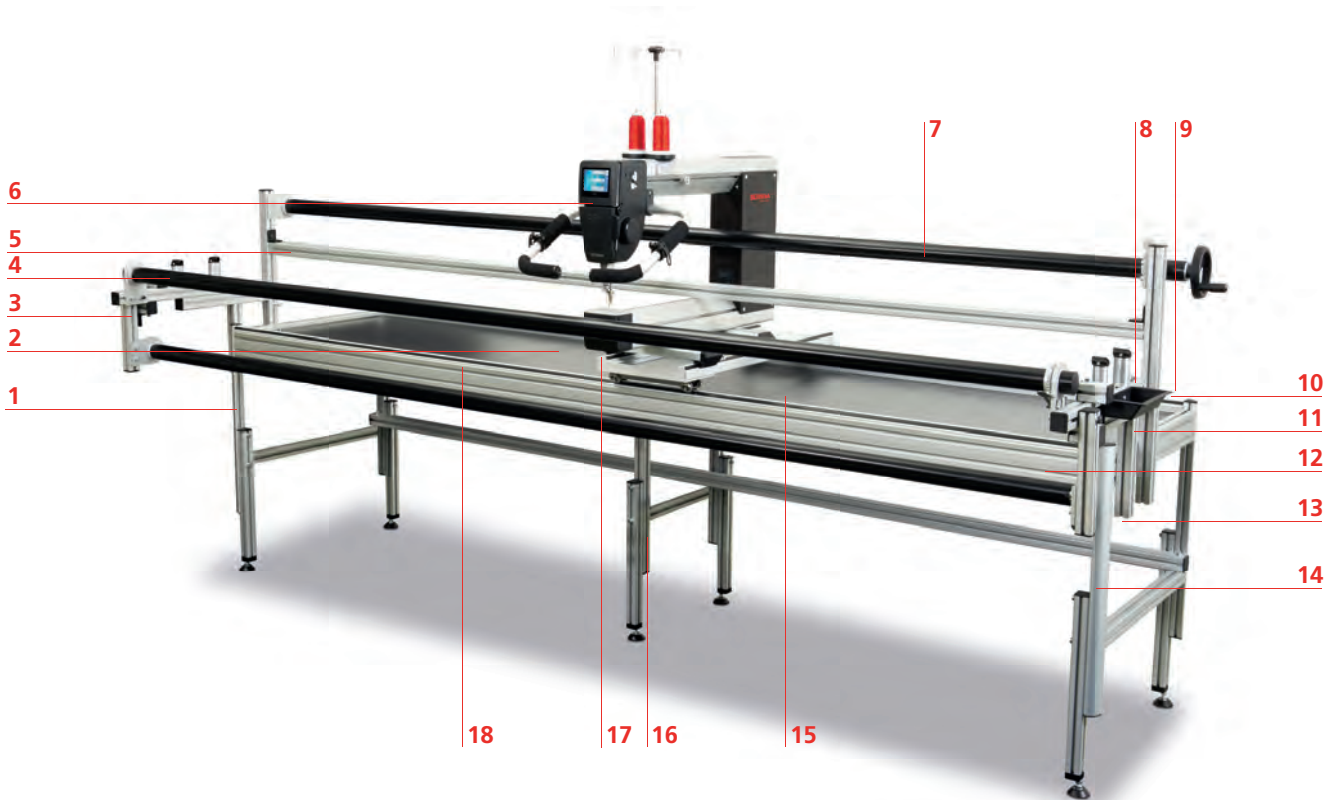

- | | | | |
|---|--------------------|----|---------------------|
| 1 | Legs, left | 10 | Cross bar, rear |
| 2 | Tabletops | 11 | Rail support, right |
| 3 | Rail support, left | 12 | Top rail |
| 4 | Backing rail | 13 | Cross bar, bottom |
| 5 | Dead bar | 14 | Legs, right |
| 6 | Machine | 15 | Track, front |
| 7 | Take-up rail | 16 | Legs, center |
| 8 | Storage tray | 17 | Carriage |
| 9 | Track, rear | 18 | Cross bar, front |

1.4 Overview of delivery

The machines in the BERNINA Q Series for quilting frames are delivered in three packages. Any special accessories ordered additionally will be supplied in separate packages. These accessories are not taken into account in these assembly instructions.

Cardboard box	Content	Size in cm (in)	Weight in kg (lb)
1	Q Series machine, including standard accessories	Approx. 112 × 77 × 42 (44.1 × 30.3 × 16.5)	Approx. 40 (88.2)
2	Large parts, tools and accessories	Approx. 120 × 80 × 70 (47.2 × 31.5 × 27.6)	Approx. 75 (165.4)
3	Long parts	Approx. 350 × 30 × 24 (137.8 × 11.8 × 9.5)	Approx. 66 (145.5)

1.5 Overview of large parts

The delivery contains the following large parts:

Cardboard box	Number	Large parts
1	1	Machine
2	3	Tabletops
	1	Carriage
	3	Legs: Right, left, center
	2	Rail supports: Right, left
3	1	Cross bar, bottom
	2	Cross bars: Rear, front
	2	Tracks: Rear, front
	1	Top rail
	1	Backing rail
	1	Take-up rail
	1	Dead bar

1.6 Overview of small parts

All small parts such as screws, nuts, washers, etc. that are required for assembly of the standard quilting frame can be found in cardboard box 2.





The parts are packaged in bags or boxes. We recommend unpacking all parts and then sorting them based on type. You can use the following tables to check the scope of delivery.

For identification purposes, each part has a code that is included in the list of parts required for the respective task in the assembly instructions.

Note: The number of items included with the small and the large quilting frame can differ from the details provided in the following tables. The differences are listed in the appendix. (see page 64)

All rights reserved: Changes with regard to the equipment of the machine can be made at any time and without advance notice for technical reasons and for the purpose of improving the product. The accessories supplied can also be subject to changes, depending on the country of delivery.

Figure	Number	Designation	Code	Tool	Use
	9	Head cap screw, M8x40	S1	Allen key no. 6	Rail support assembly (8 pcs) Carriage alignment (1 pc.)
	3	Head cap screw, M8x50	S2	Torx T30 screwdriver	Attaching the lower cross bar
	1	Countersunk screw, M5x10	S3	Allen key no. 3	Attaching the Take-up rail
	2	Head cap screw, M8x50	S4	Allen key no. 5	Assembling the Top rail
	1	Countersunk screw, M4x45, black	S5	Allen key no. 3	Carriage alignment
	16	Head cap screw, M4x16	S6	Allen key no. 3	Track assembly
	4	Button head screw, M5x12	S7	Allen key no. 3	Attaching the storage trays
	10	Countersunk screw, M8x14, black	S8	Allen key no. 5	Positioning tabletops (8 pcs) Attaching the dead bar (2 pcs)
	2	Button head screw, M6x12	S9	Torx T30 screwdriver	Carriage alignment

Figure	Number	Designation	Code	Tool	Use
	4	Head cap screw, M5x16	S10	Torx T25 screwdriver	Carriage alignment
	4	Head cap screw, M6x50	S11	Allen key no. 5	Attaching the front bar
	2	Button head self-tapping screw, 6.3x22	S12	Torx T30 screwdriver	Attaching the front track
	10	Slot nut, M6, comprising a square nut, an M6 serrated washer and a head cap screw (M6x12)	SN1	Allen key no. 5	Attaching the rear bar Attaching the front bar

Tab. 1: Overview of screws











Figure	Number	Designation	Code	Tool	Use
	1	Nut, M4	N1		Carriage alignment
	4	Hex nut, M5	N2		Carriage alignment
	6	Washer, M10	W1		Attaching adjustable leveling feet
	8	Serrated washer, M8	W2		Rail support assembly
	3	Washer, M8	W3		Attaching the lower cross bar
	1	Countersunk washer, D25	W4		Attaching the Take-up rail
	4	Serrated washer, M6	W5		Attaching the front bar
	4	Washer, 5.3/10x1	W6		Carriage alignment



Figure	Number	Designation	Code	Tool	Use
	2	Serrated lock washer, M6	W7		Carriage alignment

Tab. 2: Overview of washers, nuts

Figure	Number	Designation	Code	Tool	Use
	6	Leveling foot	M1	Open-ended wrench no. 14	Attaching adjustable leveling feet
	2	Storage tray, black	M2	–	Attaching the storage trays
	1	Handwheel, black, sticker/cover label	M3	Allen key no. 3	Attaching the Take-up rail
	1	Locking piece	M4	–	Attaching the Take-up rail
	1	Winder bolt	M5	Allen key no. 4	Attaching the Take-up rail
	2	Setting collar (with three screwed-in grub screws)	M6	Allen key no. 2	Attaching the backing rail Attaching the Take-up rail
	3	Ratchet wheel (with three screwed-in grub screws)	M7	Allen key no. 2	Attaching the backing rail Attaching the Take-up rail Attaching the Top rail
	1	Magnet, circular	M8	–	Carriage alignment
	1	Rubber cap for magnet, black	M9	–	Carriage alignment
	8	Metal bracket, black	M10	–	Positioning tabletops

Figure	Number	Designation	Code	Tool	Use
	14	Self-adhesive felt strips, black	M11	–	Positioning tabletops
	4	Cover cap for Y rails	M12	–	Carriage alignment
	4	Cover cap for X rails	M13	–	Carriage alignment
	4	Y safety bracket	M14	–	Carriage alignment
	2	X safety bracket	M15	–	Carriage alignment
	4	Bungee cord	M16	–	Attaching the side clamps
	4	Safety clips	M17	–	Attaching the side clamps
	1	Double-sided adhesive tape	M18	–	Attaching the side clamps
–	1	Back leader	–	–	Attaching the side clamps
–	1	Top leader	–	–	Attaching the side clamps
–	1	Take-up leader	–	–	Attaching the leaders

Tab. 3: Overview of various parts

Figure	Number	Designation	Code
	1	Allen key set, nine-piece	T1
	3	Open-ended wrench: 6×7, 12×14, 13×17	T2

Tab. 4: Tools supplied

2 Quilting frame assembly

2.1 Unpacking and checking the delivery

- > Open the packaging and unpack the individual parts.
- > Check the individual parts for damage.
- > Check that the delivery is complete.
- > If parts are missing or if you have any questions about the assembly, contact your specialist BERNINA dealer immediately.

2.2 Recurring steps

The following instructions describe steps that you need to perform repeatedly during assembly of the quilting frame. These steps are not described in detail each time in the assembly instructions.

Fitting the slot nuts

Slot nuts can be used to securely connect the components of the base frame to one another. A set of slot nuts (SN1) comprises the slot nut that fits into the slot on the component, a serrated washer and a screw.

- > Unscrew the screw from the slot nut.
- > Insert the slot nut into the slot near the joint. Ensure that the spring is inside and that the thread can be seen from the outside.



- > Use the Allen key to slide the slot nut in the slot so that it comes to rest precisely behind the borehole on the counterpart.



- > Place the washer onto the screw.



- > Insert the screw through the borehole and screw it into the slot nut.



- > Tighten the screw, holding the Allen key by the long end.

Tightening the socket screws

- > Always hold the Allen key by the long end when tightening the SN1, S1, S3, S4, S5, S8, and S11 screws.



2.3 Sequence of assembly steps

1. Working height adjustment. (see page 13)
2. Base frame assembly. (see page 15)
3. Rail support attachment. (see page 23)
4. Tabletop positioning. (see page 25)
5. Quilting frame levelling. (see page 26)
6. Track assembly. (see page 27)
7. Top and backing rail assembly. (see page 32)
8. Carriage and park position magnet alignment. (see page 35)
9. Machine preparation. (see page 38)
10. Take-up rail and dead bar attachment. (see page 53)
11. Leader, side clamp and storage tray attachment. (see page 55)

2.4 Working height adjustment

For optimal ergonomics and the best possible quilt quality, the height of the quilting frame can be adjusted. To adjust the quilting frame to the optimal working height, the legs must be adjusted to the correct length before assembling the frame.



CAUTION! Do not adjust the height of the quilting frame using the height-adjustable levelling feet. These are only intended for horizontal alignment of the quilting frame.

Determining the optimal working height

The optimal working height (b) is the height of the lower edge of your elbow when your arm is bent at right angles. For most people, this is around the height of the navel. The height of the quilting frame must be set so that the stitch plate on the machine is located at the optimal working height (b).

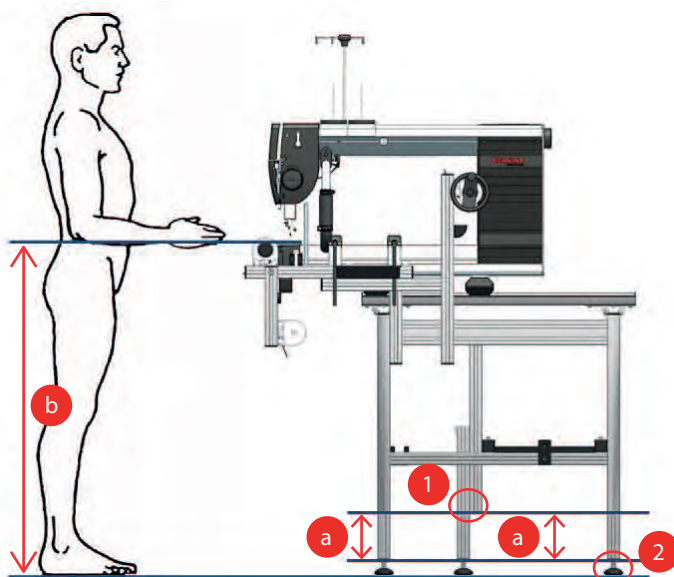

To adjust the quilting frame to the optimal working height, the legs must be adjusted to the correct length **before** assembling the frame.

On delivery, the quilting frame is set to a working height that suits persons with a height of approximately 162 to 167 cm (5'4" to 5'6").

- > For other heights, measure the distance from the lower edge of the elbow to the floor (b) with the arms at right angles.
- > The following table lists the suitable leg lengths for this.

Elbow height b (cm / inches)	Leg length a (cm / inches)*	Comment
95 / 37	5 / 2	
100 / 39	10 / 4	Delivery state
105 / 41	15 / 6	
110 / 43	20 / 8	
115 / 45	25 / 10	

*) Length of the protruding leg profile (**without** levelling feet).

Adjusting the leg length

Each leg of the quilting frame comprises two leg segments that can be moved against one another.



Required parts and tools:

- Allen key no. 6 (T1)
- Tape measure (not included in the scope of delivery)

Prerequisite:

- The optimal leg length is determined.
- > Undo the two locking screws on each leg.
 - The two leg segments can be moved against one another.
- > Move the lower leg segment until it reaches the leg length determined.



- > Tighten the locking screws.

2.5 Base frame assembly

Overview components

The following figures show the most important pre-assembled parts and components for quilting frame assembly.

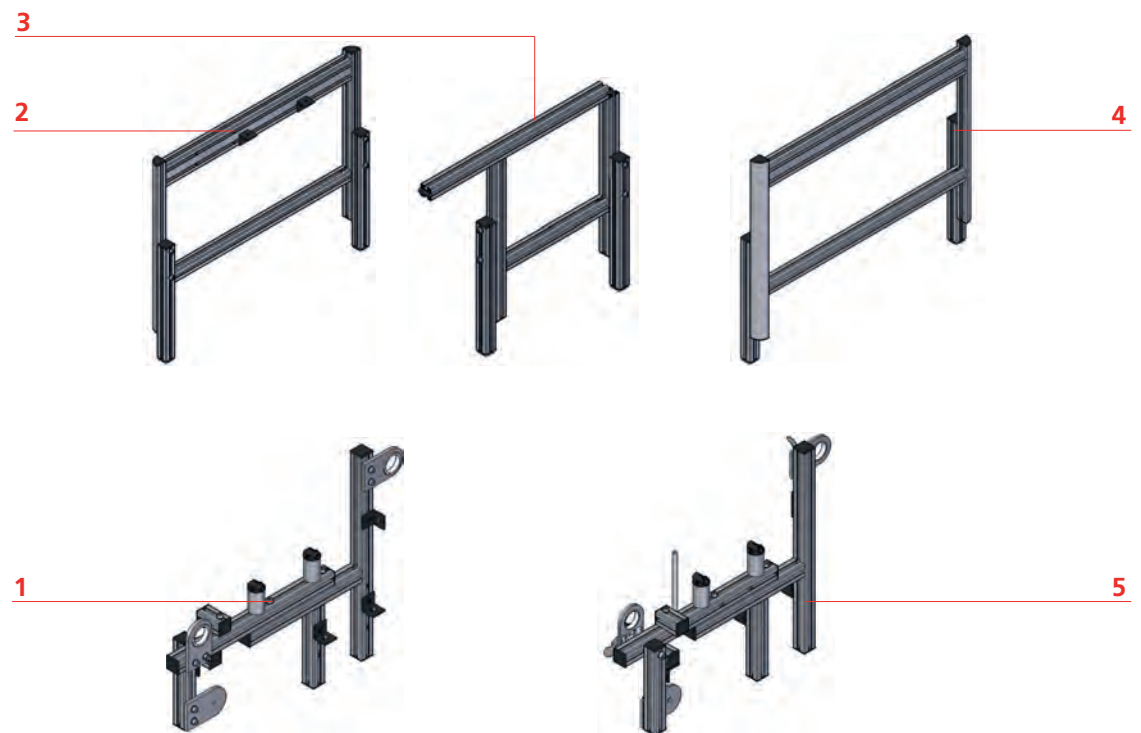

- 1 Rail support, left
- 2 Legs, left
- 3 Legs, center

- 4 Legs, right
- 5 Rail support, right



Attaching adjustable levelling feet

The adjustable levelling feet are used to level the quilting frame (see page 26). To ensure sufficient scope for precision adjustment of the height, the levelling feet must not be screwed in as far as they can go.

Required parts and tools:

- Legs, center
 - Legs, left
 - Legs, right
 - 6x levelling feet (M1)
 - 6x washers (W1)
 - Open-ended wrench no. 14 (T2)
- > Place one washer (W1) on each levelling foot (M1).
- > Screw one levelling foot onto each leg. To ensure that there is sufficient scope for precision adjustment of the height, set a distance of 5 cm (1.96 inches) between the lower edge of the profile and the lower edge of the foot.



Attaching the lower cross bar

Required parts and tools:

- Cross bar, bottom
- Legs, center
- Legs, right
- Legs, left
- 3x head cap screws M8 x 50 (S2)
- 3x washers M8 (W3)
- Allen key no. 6 (T1)

Prerequisite:

- Leg length is set.



- > Place a washer (W3) onto a head cap screw (S2). Tighten the screw.



- > Place the right-hand edge of the cross bar onto the lower longitudinal bar of the right leg in such a way that the borehole is located precisely above the pre-fitted slot nut.

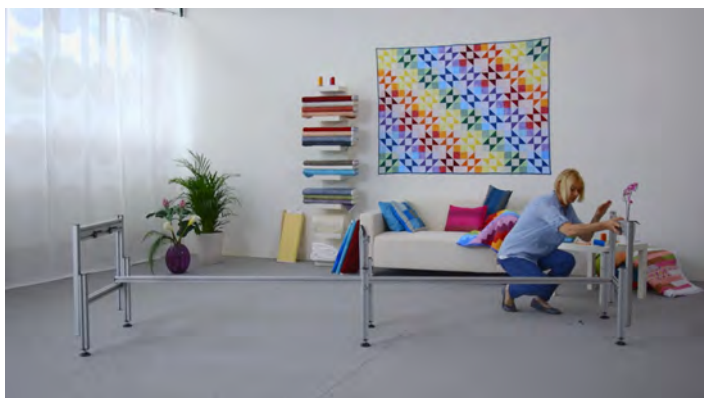

- > Place a washer (W3) onto a head cap screw (S2). Tighten the screw.

Attaching the back bar

Required parts and tools:

- Cross bar, rear
- 8x slot nuts (SN1)
- Allen key no. 5 (T1)

Moving the upper longitudinal bar on the central leg

The upper longitudinal bar on the central leg must be moved so that the rear cross bar can be fitted.

- > Use the Allen key (T1) to undo the two screws in the lower slot on the right and left of the front leg and then push the longitudinal bar slightly forward.



Positioning the rear cross bar

- > Place the cross bar onto the central leg in such a way that the inserted slot nuts are located in the lower slot and point inward. The "TOP" sticker faces upward.

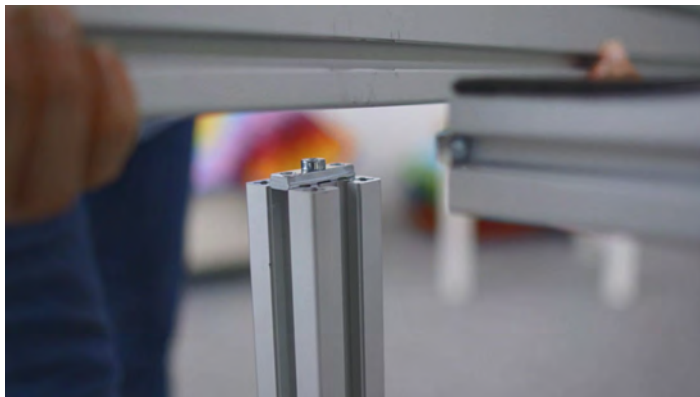

- > Move the inserted slot nuts in such a way that there are the same number of slot nuts to the right and the left of the central leg.



- > Insert the rear cross bar into the slot of the left leg in such a way that the upper edges of the rear cross bar and the left-hand longitudinal bar are at the same height.



- > Insert the rear cross bar into the slot of the right leg in such a way that the upper edges of the rear cross bar and the right-hand longitudinal bar are at the same height.



Attaching the rear cross bar to the right and left leg

Carry out the following tasks on both sides.

- > Attach a slot nut (SN1) to the top edge of the cross bar. (see page 12)
- > Check to ensure that the cross bar and longitudinal bar are at the same height.
- > If necessary, align the rear cross bar.
- > Tighten the screw. (see page 13)

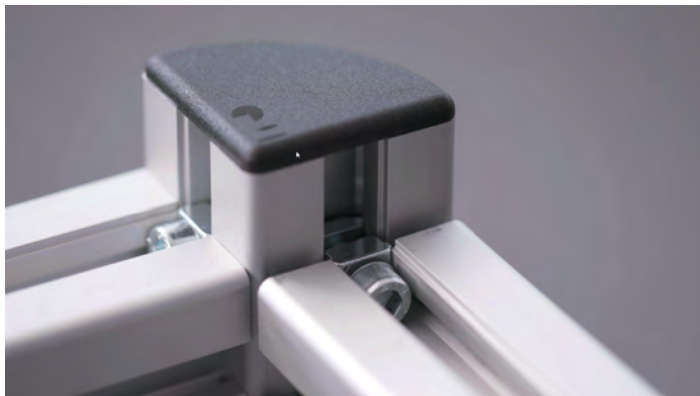

- > Attach a slot nut (SN1) to the bottom edge of the cross bar.



Attaching the rear cross bar to the central leg

- > Push the upper longitudinal bar on the central leg backward again so that it fits into the lower slot on the internal surface of the cross bar.
- > Attach one slot nut (SN1) each in the lower slot of the cross bar to the right and the left of the longitudinal bar.



- > Attach one slot nut (SN1) each in the slot on the lower edge of the cross bar to the right and the left of the central leg.



Attaching the front bar

Required parts and tools:

- Cross bar, front
- 2x slot nuts (SN1)
- 4x head cap screws M6x50 (S11)
- 4x serrated washers M6 (W5)
- Allen key no. 5 (T1)

Positioning the front cross bar

- > Place the cross bar onto the central leg in such a way that the inserted slot nuts are located in the lower slot and point inward. The "TOP" sticker faces upward.



2.6 Rail support assembly

Attaching rail supports

Required parts and tools:

- Rail support, left
- Rail support, right
- 8x head cap screws M8x40 (S1)
- 8x serrated washers M8 (W2)
- Allen key no. 6 (T1)

Carry out the following tasks on both sides.

- > Hold the rail support against the leg from the outside in such a way that the head cap screws (S1) can be screwed into the pre-fitted slot nuts on the rail support.



- > Place one serrated washer (W24) onto each of the four head cap screws (S1).
- > Screw the head cap screws (S1) into the screw holes on the leg from the inside and only tighten them to the point where the rail support can still be moved.



- > Slide the rail support downward and forward until the two metal brackets (M10) rest on the longitudinal bar of the leg.



- > Tighten the head cap screws (S1) (see page 13).



Adapting the rail support for BERNINA Q 20

Required parts and tools:

- Allen key no. 6 (T1)

Carry out the following tasks on both sides.

- > Undo the two screws on the top of the rail support.



- > Push the front part of the movable bar toward the vertical profile as far as it will go.



- > Tighten the two screws.



- > Position the metal brackets (M10) so that two tabletops rest on each bracket. Tighten the screws (see page 13).



- > Place the tabletops onto the metal brackets (M10) so that the tabletops are stable.



- > If necessary, carefully undo the metal brackets (M10) and reposition them.

2.8 Quilting frame levelling

To allow the machine to move smoothly on the quilting frame, the quilting frame must be aligned perfectly horizontally using the levelling feet after assembly.

Required parts and tools:

- Open-ended wrench no. 17 (T2)
 - Spirit level (not included in the scope of delivery)
- > Move the quilting frame into the final position for quilting.
 - > Screw in the levelling feet (M1) on the central leg until they no longer touch the floor.
 - > Use the spirit level to check the horizontal alignment of the quilting frame. If necessary, shorten the lateral leg lengths by screwing in the levelling feet (M1) or extend them by unscrewing the feet.
 - > As soon as the quilting frame has been levelled, unscrew the levelling feet (M1) on the central leg so that they touch the ground firmly and the quilting frame is well supported.



- > Tighten the counternuts on all six legs.

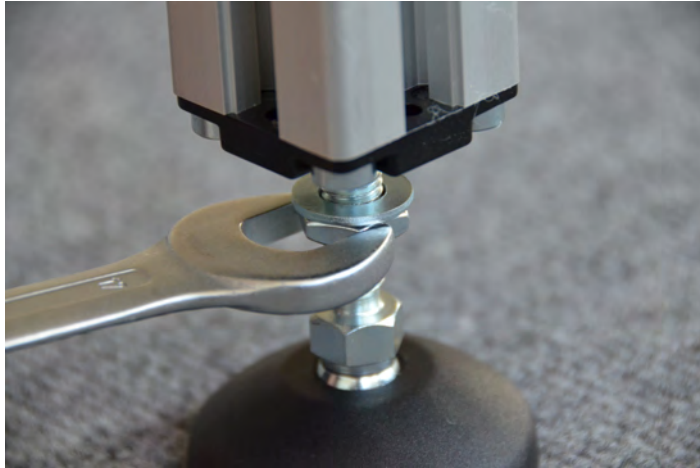

2.9 Track assembly

Attaching the rear track

Required parts and tools:

- 8x head cap screws M4×16 (S6)
- 1x track
- 2x black plastic inserts
- Allen key no. 3 (T1)

- > Pull the two black plastic inserts out of the tracks.

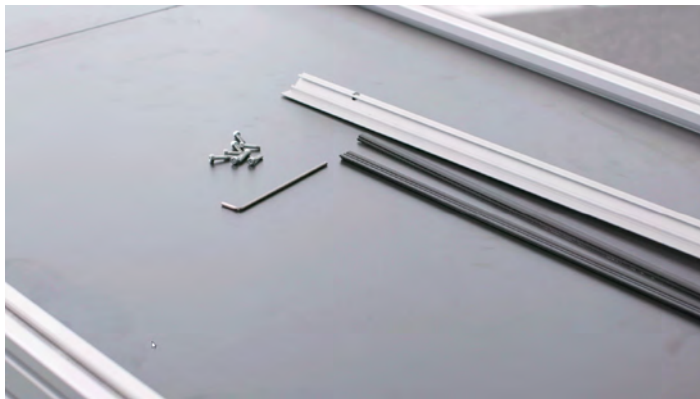

- > Insert the head cap screws (S6) into the holes on the track one after the other.



- > To ensure that the carriage later rests optimally on the tracks, pull the track outwards and then tighten all head cap screws (S6).



Attaching the front track

Required parts and tools:

- 8× head cap screws M4×16 (S6)
- 2× button head self-tapping screws 6.3×22 (S12)
- 1× track
- 2× black plastic inserts
- Allen key no. 3 (T1)
- Torx screwdriver no. T30 (included in the box with the machine)

- > Pull the two black plastic inserts out of the tracks.

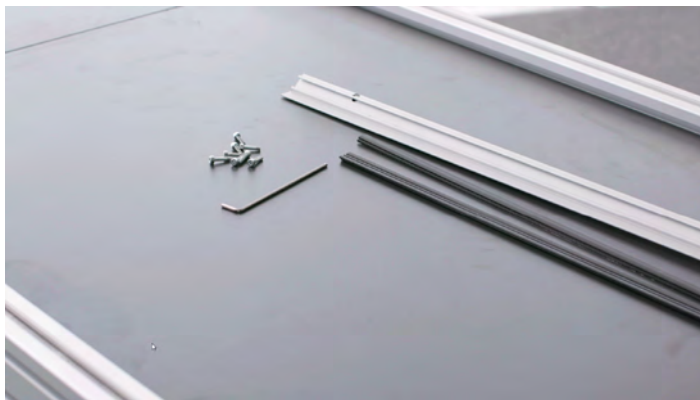

- > Insert the head cap screws (S6) into the holes on the track one after the other.



Assembling the top rail

Required parts and tools:

- Top rail
- Ratchet wheel (M7)
- 2× head cap screws M8×50 (S4)
- Allen key no. 2 and no. 6 (T1)

> Push the ratchet wheel (M7) over the right-hand end of the top rail so that the teeth are pointing forward when viewed from the front of the quilting frame.



> Hold the top rail and inner bar with the pre-fitted plastic cap precisely in front of the screw hole on the lower rail bracket of the right-hand rail support.

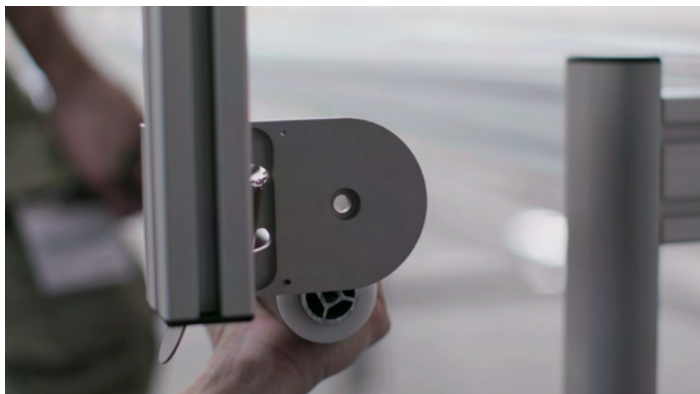

> Insert the head cap screw (S4) through the screw hole and tighten it.



> Repeat the last two steps on the left-hand side.

> Push the ratchet wheel (M7) under the pawl as close as possible to the rail support. However, the ratchet wheel must not brush against the rail support.



- > Tighten the pre-fitted grub screws so that the rail and ratchet wheel are securely connected to one another.



Assembling the backing rail

Required parts and tools:

- Backing rail
- 1× setting collar (M6)
- 1× ratchet wheel (M7)
- Allen key no. 2 (T1)

- > Push the setting collar (M6) over the left-hand end of the backing rail.





- > Push the ratchet wheel (M7) over the right-hand end of the backing rail so that the teeth are pointing backward when viewed from the front of the quilting frame.



- > Push both ends of the backing rail into the upper rail brackets of the rail supports.
- > Align the backing rail centrally.
- > Push the setting collar (M6) up close to the left-hand rail support. The setting collar must not, however, brush against the rail support.
- > Tighten the pre-fitted grub screws so that the rail and setting collar are securely connected to one another.



- > Push the ratchet wheel (M7) under the pawl as close as possible to the rail support. However, the ratchet wheel must not brush against the rail support.
- > Tighten the pre-fitted grub screws so that the rail and ratchet wheel are securely connected to one another.



2.11 Carriage and park position magnet alignment

Positioning the carriage

Required parts and tools:

- Carriage

- > Position the carriage on the tracks so that the hole for the park position magnet (M8) is pointing to the left when viewed from the front.



- > Guide the carriage along the tracks, while checking the contact of the wheels to the tracks with your fingers.



- > If the carriage does not slide smoothly over the tracks, or if not all wheels are in contact with the tracks at all times, the carriage needs to be realigned.

Aligning the carriage

Required parts and tools:

- Allen key no. 4 (T1)









2.12 Machine preparation

Overview

Required parts and tools:

- BERNINA Q Series machine
- 2× stand profiles
- Accessories for stand profiles
- 4× V-wheel units (P16) (carriage accessories, cardboard box 2)
- Allen key no. 5 (T1)
- Torx screwdrivers (T20 and T25) (included in the box with the BERNINA Q Series machine)
- Slotted screwdriver, medium-sized (not included in the scope of delivery)

Figure	Number	Designation	Code	Tool	Use
	1	Stand profile, front	P1		Attaching the front stand profile
	1	Stand profile, rear	P2		Attaching the rear stand profile
	1	Damping mat	P3		Attaching the front stand profile
	1	Aluminum plate	P4		Attaching the rear stand profile
	1	Circular sleeve	P5		Attaching the front stand profile
	1	Threaded bolt, short	P6		Attaching the front stand profile
	1	Spring washer	P7		Attaching the front stand profile
	1	Washer	P8		Attaching the front stand profile
	1	Serrated lock washer	P9		Attaching the rear stand profile

Figure	Number	Designation	Code	Tool	Use
	1	Head cap screw	P10	Torx T25 screwdriver	Attaching the rear stand profile
	1	Head cap screw	P11	Allen key no. 5 (T1)	Attaching the front stand profile
	2	Head cap screw	P12	Torx T20 screwdriver	Attaching the rear stand profile
	1	Washer, thick, small	P13		Attaching the front stand profile
	1	O-ring	P14		Attaching the front stand profile
	1	Washer, thick, large	P15		Attaching the front stand profile
	4	V-wheel units	P16	Allen key no. 4 (T1)	Attaching the V-wheel units

Tab. 5: Overview of parts for machine assembly

Overview of assembly

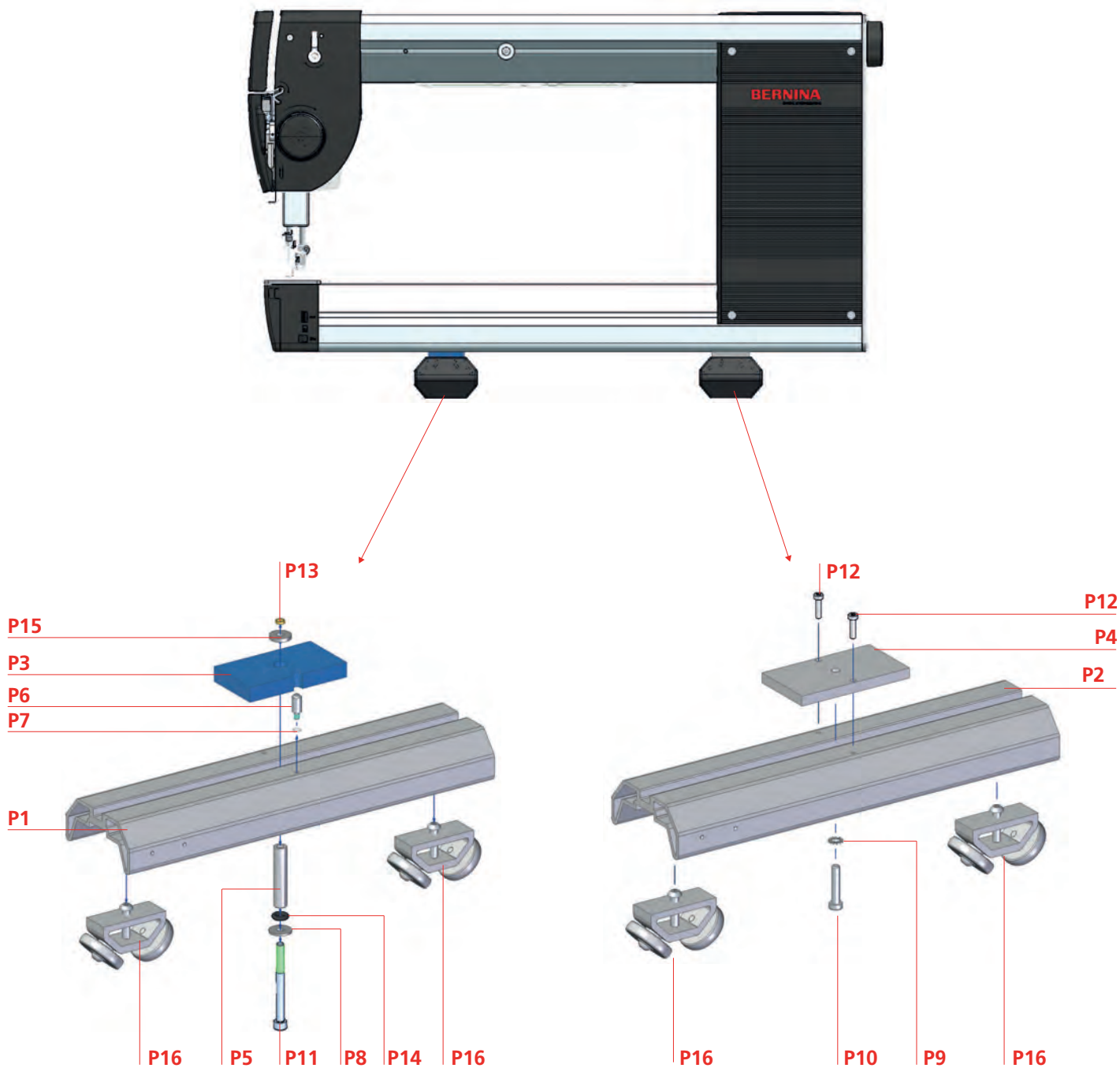

Important notes on the stand profiles

Both stand profiles have a round hole on one side and a slotted opening on the other side for attaching the V-wheels. The slotted opening allows the V-wheels to be subsequently aligned, so that they rest perfectly on the tracks of the carriage. Please therefore make sure that the slotted opening on both stand profiles is on the same side of the machine after assembly.

The front stand profile differs from the rear stand profile due to a plastic stud on the underside, i.e. the stand profile with the plastic stud must be fitted at the front of the machine.



Sequence of assembly steps

1. Getting the machine ready (see page 41)
2. Attaching the V-wheel units (see page 41)
3. Attaching the front stand profile (see page 42)
4. Attaching the rear stand profile (see page 44)
5. Positioning the machine on the carriage (see page 46)
6. Attaching safety brackets (see page 47)
7. Fitting rail covers (see page 49)

Getting the machine ready



The machine can easily tip over without stand profiles

Risk of injury and damage to the machine.

> Carefully put the machine in a position where it is stable.

> Lay the machine down on its side at the edge of a fixed base, such as a tabletop.



Attaching the V-wheel units

Attach the V-wheel units to both stand profiles.

Required parts and tools:

- 4x V-wheel units (P16)
- Stand profile, front (P1)
- Stand profile, rear (P2)
- Allen key no. 4 (T1)
- Tape measure (not included in the scope of delivery)

Perform the following work for both stand profiles.

> Remove the screws and washers from the V-wheel units (P16).

- > Position the V-wheel unit under the outer round hole, insert the screw from above and then tighten it.

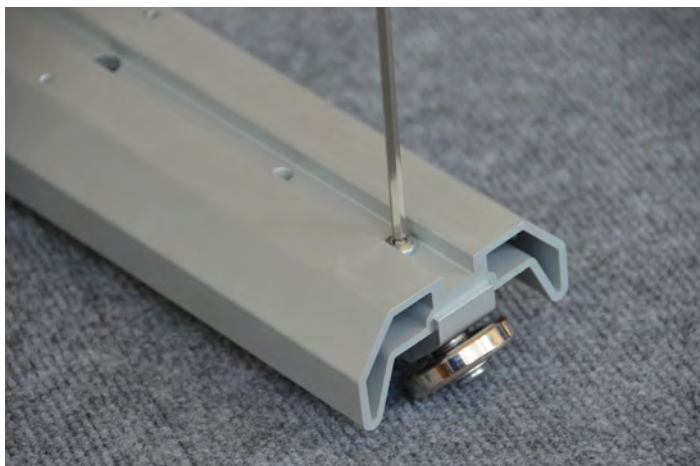

- > On the other side of the profile, position the V-wheel unit (P16) below the slot so that the distance from the left-hand screw head to the right-hand screw head is approximately 28 cm (11 inches).
- > Insert the screw and washer from above, but only tighten the screw slightly so that the V-wheel unit can still be moved.



Attaching the front stand profile

NOTICE

Machine damage due to undoing screws on the underside of the machine

Parts of the machine can fall out.

- > Do not undo any screws on the underside of the machine.

Assembling the front stand profile

Required parts and tools:

- Stand profile, front (P1)
- Damping mat (P3)
- Circular sleeve (P5)
- Threaded bolt (P6)
- Spring washer (P7)
- Washer (P8)
- Head cap screw (P11)
- Washer, thick, small (P13)
- O-ring (P14)
- Washer, thick, large (P15)

- Slotted screwdriver, medium-sized (not included in the scope of delivery)
- > Push the spring washer (P7) over the thread on the short threaded bolt (P6).
- > Screw the threaded bolt into one of the two smaller holes in the center of the front stand profile and tighten it using the slotted screwdriver.



- > Hold the long screw (P11) by its head and then push the washer (P8), black O-ring (P14) and circular sleeve (P5) onto the screw (P11) one by one in sequence. Position the circular sleeve (P5) so that the chamfer points downward toward the head of the screw (P11).
- > Guide the long screw into the large hole in the plastic stud on the stand profile from below.



- > Place the blue damping mat (P3) onto the screw from above so that the lateral recess encircles the threaded bolt.
- > Push the large, thick washer (P15) and the small, thick washer (P13) onto the screw in sequence.



Attaching the front stand profile

Required parts and tools:



- Assembled stand profile
- Allen key no. 5 (T1)

Prerequisite:

- The machine is on its side (see page 41).
- > Screw the screw (P11) into the thread on the front slot nut, but only tighten it slightly so that the profile can still be moved.
- > Move the stand profile so that the arrow tip printed on the machine profile touches the edge of the damping mat (P3).
- > Tighten the screw (P11).



Attaching the rear stand profile

NOTICE

Machine damage due to undoing screws on the underside of the machine

Parts of the machine can fall out.

- > Do not undo any screws on the underside of the machine.

Required parts and tools:

- Stand profile, rear (P2)
- Aluminum plate (P4)
- Washer (P9)
- Head cap screw (P10)
- 2x head cap screws (P12)
- Torx T20 and T25 screwdrivers

- > Place the aluminum plate (P4) onto the center of the rear stand profile from above.



Positioning the machine on the carriage



Risk of injury from improper transport

Risk of injury and damage to the machine.

- > Position the machine on the carriage with the help of another person.
- > Leave the machine in the park position until the dead bar and take-up rail have been fitted.

Required parts and tools:

- Machine with stand profiles fitted
- 4x lateral cover caps (M13)
- Allen key no. 4 (T1)

- > Position the machine on the carriage with the help of another person.



- > Check to ensure that the machine can be moved freely along the entire length of the carriage and that all wheels are in contact with the carriage at all times.
- > If necessary, readjust the position of the V-wheel units (P16) and then tighten the screws.



- > Attach the lateral cover caps (M13) to the ends of the stand profiles.





- > Carefully push the machine up to the left-hand rail support and into the park position.



Attaching safety brackets

The machine is secured from tipping over with two types of safety brackets:

- Y safety brackets secure the machine on the carriage and are fitted to the machine's stand profiles.
- X safety brackets secure the carriage on the quilting frame and are fitted to the carriage.

Attaching Y safety brackets

Attach the four Y safety brackets to the two stand profiles of the machine on both sides.

Required parts and tools:

- 4x Y safety brackets (M14)
 - 4x washers 5.3/10x1 (W6)
 - 4x head cap screws Torx M5x16 (S10)
 - 4x hex nuts M5 (N2)
 - Torx screwdriver (T25)
 - Open-ended wrench no. 8 (T2)
- > Guide one head cap screw (S10) with washer attached (W6) through the borehole behind the rail in the stand profile from above.
 - > Push one Y safety bracket (M14), with the slot facing upward, over the screw from below.



- > Loosely tighten the hex nut (N2) from below, with the ribbed surface facing upward.

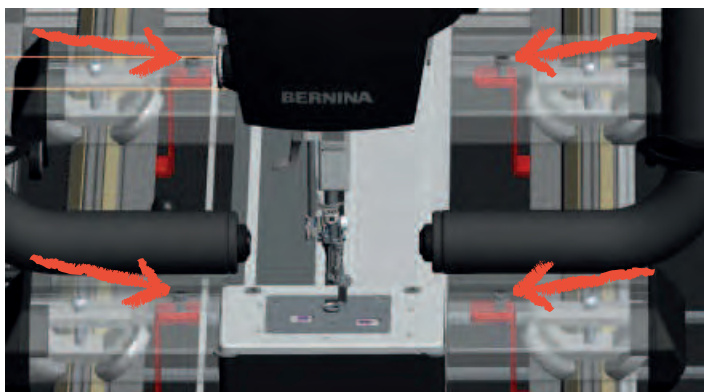

- > Push the Y safety bracket (M14) all the way up to the rail and then pull it approximately 1 mm back.
 - The Y safety bracket does not touch the rail.

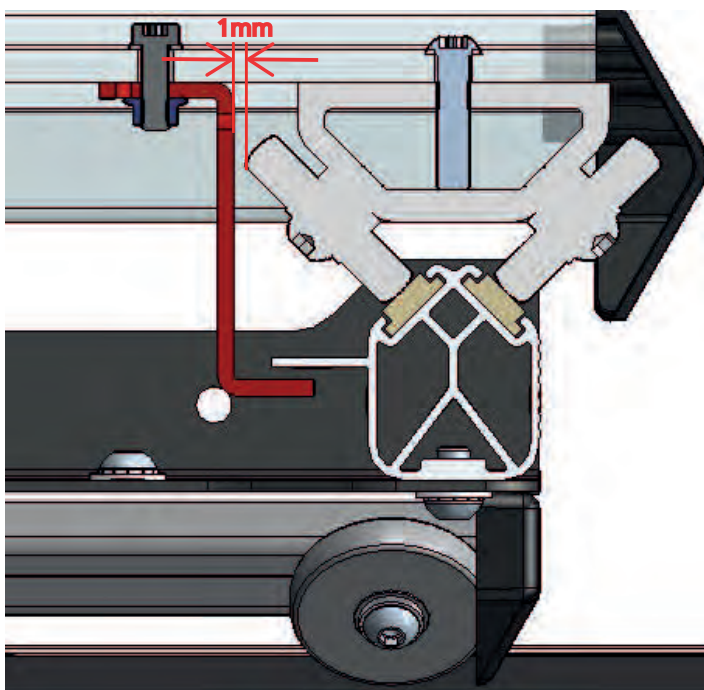

- > Hold the threaded nut securely with the open-ended wrench and then tighten the head cap screw (S10).
- > Attach the other three Y safety brackets (M14) the same way.

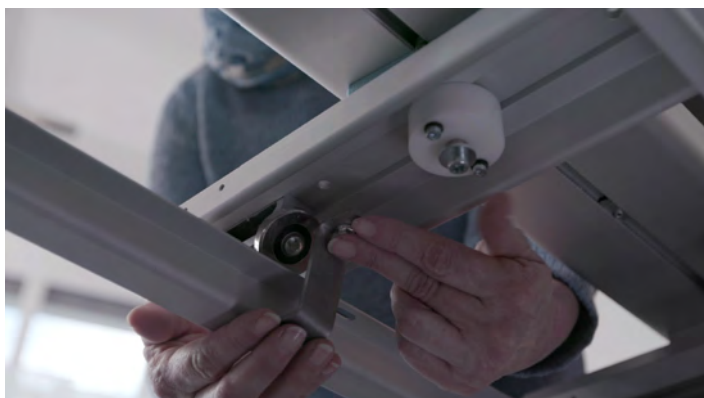

- > Attach the rail covers to the ends of the rail pair brackets on the carriage, pressing them as far as they will go.



2.13 Take-up rail and dead bar attachment

Attaching the Take-up rail



Risk of injury from falling machine

Risk of injury and damage to the machine.

- > Leave the machine in the park position until the dead bar and the take-up rail have been fitted.
- > Always take care when moving the machine or carriage.

Required parts and tools:

- Take-up rail
- 1x setting collar (M6)
- 1x ratchet wheel (M7)
- Allen key no. 2 (T1)

- > Push the setting collar (M6) over the left-hand end of the take-up rail.



- > Push the ratchet wheel (M7) over the right-hand end of the take-up rail so that the teeth of the ratchet wheel are pointing backward when viewed from the front of the quilting frame.

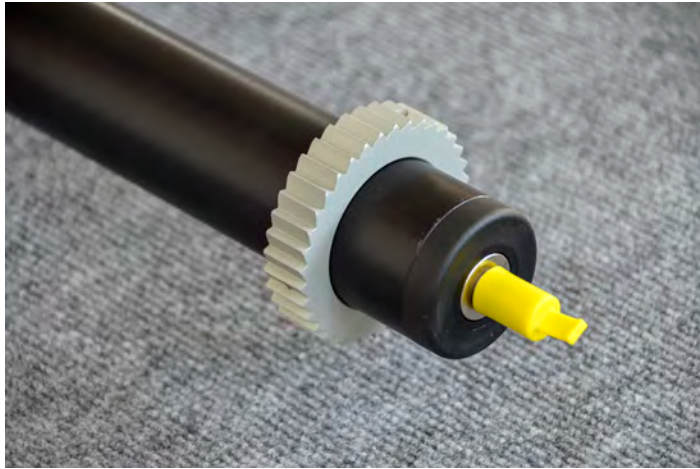

- > Guide the take-up rail through the neck of the machine.
- > Guide the two ends of the take-up rail through the rear rail brackets of the rail supports.
- > Align the take-up rail centrally.



- > Push the setting collar (M6) up close to the left-hand rail support. The setting collar must not, however, brush against the rail support.
- > Tighten the pre-fitted grub screws so that the rail and setting collar are securely connected to one another.

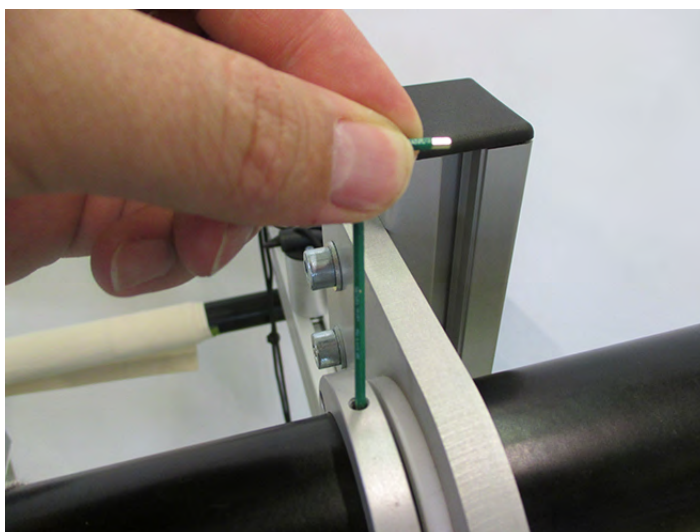

- > Slide the ratchet wheel (M7) under the pawl as close as possible to the rail support.



- > Push the countersunk screw washer (W4) onto the countersunk screw (S3).
- > Insert the screw into the screw hole and tighten it carefully.



- > Cover the countersunk screw (S3) with a sticker.



- > Screw the winder bolt (M5) to the handwheel (M3).



Attaching the dead bar



Risk of injury from falling machine

Risk of injury and damage to the machine.

- > Leave the machine in the park position until the dead bar and the take-up rail have been fitted.
- > Always take care when moving the machine or carriage.

Required parts and tools:

- Dead bar

- 2x countersunk screws M8x14 (S8)
 - Allen key no. 5 (T1)
- > Guide the dead bar through the neck of the machine with the rounded off side facing backward.
- > Carry out the following tasks on both sides.
- > Position the dead bar behind the pre-fitted rail support bracket so that the slot nut in the dead bar sits precisely behind the screw hole in the bracket.



- > Insert the countersunk screw (S8) into the screw hole and tighten it.



Checking/adjusting the height of the dead bar

The dead bar must be attached at the correct height relative to the machine.

If the dead bar is attached too low, the machine will brush when moving. If it is attached too high, the distance between the material and the BSR sensors is too great. The sensors cannot measure the movement of the machine correctly and the stitch length is not adjusted correctly.

The dead bar is attached at the optimal height when a no. 6 (T1) Allen key just fits between the dead bar and the machine.

Required parts and tools:

- Allen key no. 5 (T1)
 - Allen key no. 6 (T1)
- > To check the height of the dead bar, first move the machine to the left-hand edge of the quilting frame.
- > Place Allen key no. 6 (T1) between the machine and the dead bar.
- > If the distance between the dead bar and the Allen key is too great or too small, adjust the height of the dead bar.
- > To adjust the height of the dead bar, undo the countersunk screw on the pre-fitted bracket in the rail support until the bracket can be moved.
- > Move the bracket so that the dead bar just touches the no. 6 Allen key (T1) on the machine.



- > Tighten the countersunk screw.
- > Remove Allen key no. 6 (T1).
- > Move the machine to the right-hand edge of the quilting frame.
- > Repeat the test and height adjustment process.

2.14 Leader, side clamp, and storage tray attachment

General notes on attaching the leaders

- Each leader has one printed and one unprinted side.
- Each leader must be attached securely to the center of the respective rail.
- All leaders are attached using double-sided adhesive tape.
- The leaders are wound onto the rails in different directions.

Check the following figure to see how the various leaders need to be attached to their respective rails. Printed side facing up or down, clockwise or anticlockwise winding direction.

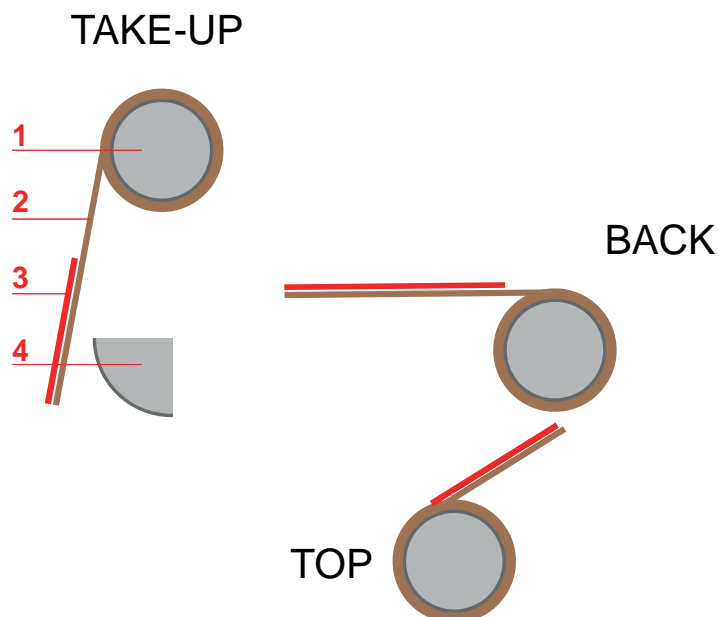

Fig. 1: Rails, viewed from the left-hand side of the quilting frame

- | | | | |
|---|--------|---|--------------------|
| 1 | Rail | 3 | Printed side (red) |
| 2 | Leader | 4 | Dead bar |

Sequence of assembly steps

Attach the leaders in the following sequence:

1. Attaching the back leader
2. Attaching the take-up leader
3. Attaching the top leader

Attaching the Back leader

Required parts and tools:

- Back leader
- Double-sided adhesive tape (M18)
- Pencil (not included in the scope of delivery)
- Tape measure (not included in the scope of delivery)

- > Determine the center of the backing rail using the tape measure and mark this position with a pencil.
- > Measure and then use a pencil to mark out a point 155 cm (61 inches) to the left and the right of the marked center.
- > Attach double-sided adhesive tape (M18) from the left-hand marking all the way to the right-hand marking. Be sure to attach the tape straight without any kinks.

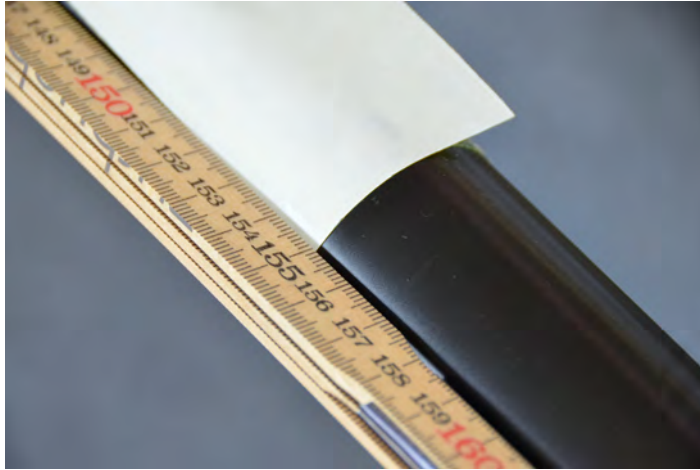

- > Remove the protective film on the top of the adhesive tape.
- > Unfold the back leader so that the material is suspended between the rail and the quilting frame and the printed side is pointing backward toward the quilting frame.
- > Position the center line of the back leader (dark broken line) on the marked center of the backing rail.

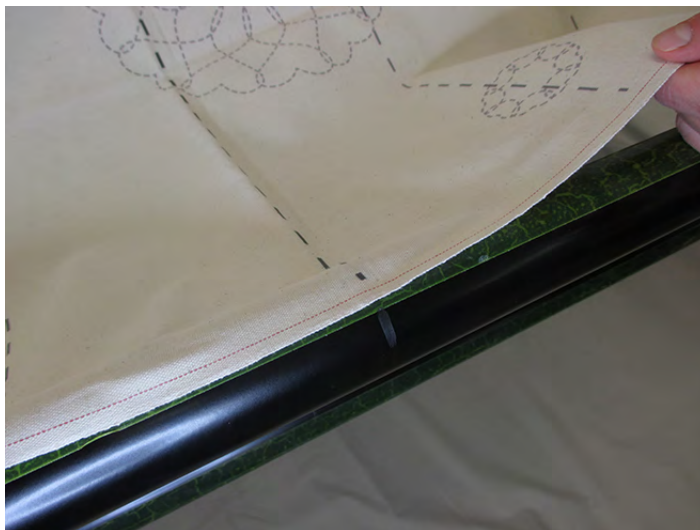

- > Attach the leader to the adhesive tape, working from the center outward to the left and right. Make sure you guide the edge of the material precisely along the edge of the adhesive tape.
- > Press the leader firmly onto the adhesive tape and roll it up.
- > Trim any excess adhesive tape.

Attaching the Take-up leader

Required parts and tools:

- Take-up leader
- Double-sided adhesive tape (M18)
- Pencil (not included in the scope of delivery)
- Tape measure, quilting guide or ruler (not included in the scope of delivery)



- > To mark the center of the take-up rail, unroll the back leader. Using a quilting guide, first transfer the center of the back leader onto the dead bar and from there onto the take-up rail. Make sure that everything is aligned correctly at right angles.

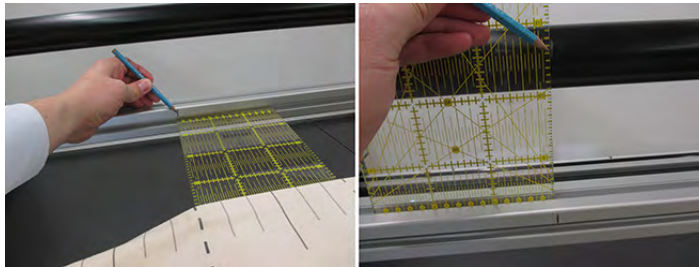

- > Fit the take-up leader from the back of the quilting frame.
- > Measure and then use a pencil to mark out a point 155 cm (61 inches) to the left and the right of the marked center.
- > Attach double-sided adhesive tape (M18) from the left-hand marking all the way to the right-hand marking. Be sure to attach the tape straight without any kinks.
- > Remove the protective film on the top of the adhesive tape.
- > Unfold the take-up leader so that the material is suspended between you and the rail and the printed side is pointing toward you.
- > Position the center line of the take-up leader (dark broken line) on the marked center of the take-up rail.
- > Attach the leader to the adhesive tape, working from the center outward to the left and right. Make sure you guide the edge of the material precisely along the edge of the adhesive tape.
- > Press the leader firmly onto the adhesive tape and roll it up.
- > Check to ensure that the center of the take-up leader and the back leader line up precisely. If necessary, reposition the take-up leader.
- > Trim any excess adhesive tape.

Attaching the Top leader

Required parts and tools:

- Top leader
 - Double-sided adhesive tape (M18)
 - Pencil (not included in the scope of delivery)
 - Tape measure (not included in the scope of delivery)
- > Fit the top leader from the front of the quilting frame.
 - > To mark the center of the top rail, unroll the back leader and pull it straight to the top rail.



- > Transfer the center position of the unrolled back leader onto the top rail.

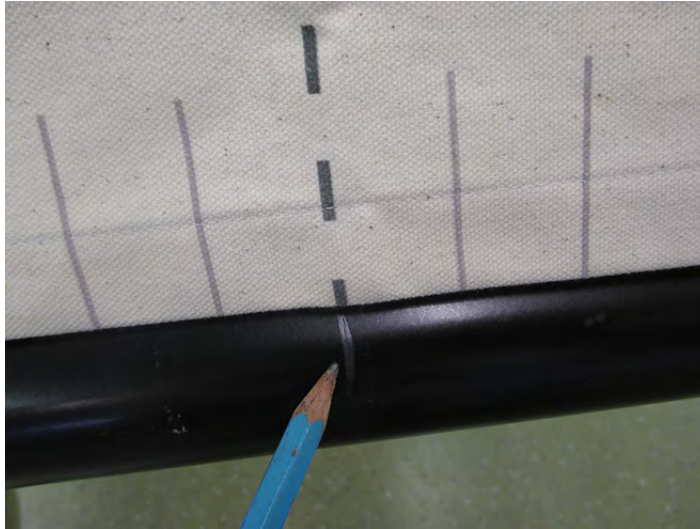

- > To make it easier to fit the top leader, swing the top rail upward.
- > Measure and then use a pencil to mark out a point 155 cm (61 inches) to the left and the right of the marked center.
- > Attach double-sided adhesive tape (M18) from the left-hand marking all the way to the right-hand marking. Be sure to attach the tape straight without any kinks.
- > Unfold the top leader so that the material is suspended between you and the rail and the printed side is pointing toward you.
- > Position the center line of the top leader (dark broken line) on the marked center of the top rail.
- > Attach the leader to the adhesive tape, working from the center outward to the left and right. Make sure you guide the edge of the material precisely along the edge of the adhesive tape.
- > Press the leader firmly onto the adhesive tape and roll it up.
- > Check to ensure that the center of the top leader and the back leader line up precisely. If necessary, reposition the top leader.
- > Trim any excess adhesive tape.
- > Swing the top rail back down again.

Attaching the side clamps

Required parts and tools:

- 4x bungee cords (M16)
- 4x safety clips (M17)

- > Guide the bungee cord (M16) through the bracket on the left-hand rail support from inside to outside.
- > Attach the safety clip (M17) to the end of the bungee cord (M16).



2.15 Front handle attachment

Attaching the front handle unit

- > Screw the handle unit behind the head of the machine with the two screws from below so that the locking levers point backward.

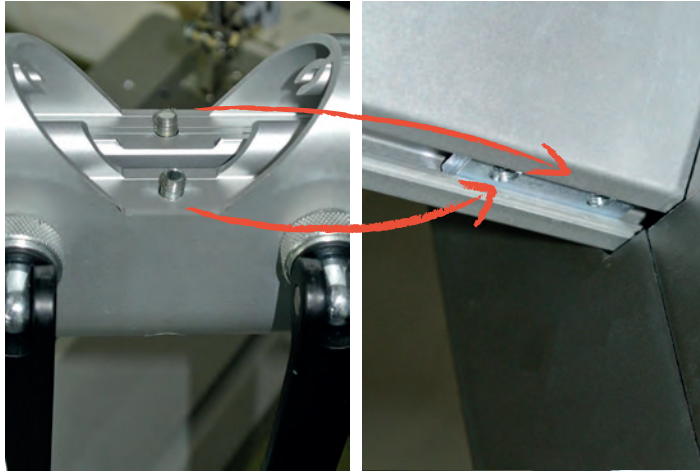

- > Insert the cable of the handle unit into the connection at the back on the head of the machine.



Adjusting the width of the handles

NOTICE! To ensure that the thread does not get caught up on the locking lever when winding, always adjust the locking levers so that they point vertically downward when clamped.

Carry out the following tasks on both sides.

- > Swing up the locking lever on the bracket of the handle.
- > Move the handle to the side until the required handle width has been reached.
- > Adjust the inclination of the handle so that the handle is at a suitable height.
- > Only tighten the locking ring (1) to a point where the locking lever can still be swung down with force.



3 Disposal

3.1 Quilting frame disposal

BERNINA International AG is committed to environmental protection. We make every effort to increase the environmental friendliness of our products by continually improving their design and production technology.

If you no longer require your quilting frame, please clean it, sort the components according to material and then dispose of these in line with local regulations and legislation.

Do not dispose of the quilting frame in household waste. If you are in any doubt, first dismantle the quilting frame and then take it to your nearest BERNINA specialist.



5 Appendix

5.1 Differing information for the "Large" quilting frame

Overview of large parts (see page 7)

5x tabletops: 3x large, 2x small

Overview of small parts (see page 8)

- 12x metal brackets (M10)
- 16x felt strips (M11)
- 12x countersunk screws M8x14 (S8)

Attaching tabletop brackets (see page 25)

> Fit the 12 metal brackets (M10) with 12 countersunk screws M8x14 (S8).

Positioning tabletops (see page 25)

- > Attach the 16 felt strips (M11).
- > Position three large tabletops in the center, with one small tabletop each on the right and the left.

Attaching the leaders (see page 55), (see page 56), (see page 57)

In the step entitled «Measure and then use a pencil to mark out a point 155 cm/61 inches to the left and the right of the marked center.», use the following values: 170 cm/67 inches

5.2 Differing information for the "Small" quilting frame

General overview (see page 6)

Point 16 «Legs, center» is no longer applicable.

Overview of large parts (see page 7)

Just two legs, on the right and the left

Overview of small parts (see page 8)

- 12x head cap screws M4x16 (S6)
- 2x head cap screws M8 x 50 (S2)
- 4x slot nuts (SN1)
- 4x washers (M10)
- 2x washers M8 (W3)
- 4x leveling feet

Attaching adjustable leveling feet (see page 16)

No legs, center, only four leveling feet (M1) and washers (W1)

Overview of assemblies (see page 15)

Point 3 «Legs, center» is no longer applicable

Attaching the lower cross bar (see page 16)

Just two legs, on the right and the left

Just two head cap screws M8 × 50 (S2)

Just two washers M8 (W3)

Do not perform any steps in the instructions that affect the central leg.

Attaching the rear cross bar (see page 18)

- Just four 4× slot nuts (SN1) are required
- Do not carry out the tasks described in the instructions entitled «Moving the upper longitudinal bar on the central leg».
- Work described in the instructions entitled «Positioning the rear cross bar»: Do not perform steps 1 and 2.
Step 4 new: «Insert the rear cross bar into the slot on the left leg in such a way that the inserted slot nuts are located in the lower slot and point inward, and the "TOP" sticker faces upward.»
- Do not perform the work described in the instructions entitled «Fitting the rear cross bar on the central leg».

Attaching the front cross bar (see page 21)

- No slot nuts required.
- Do not carry out the tasks described in the instructions entitled «Fitting the front cross bar on the central leg».

Quilting frame levelling (see page 26)

Do not carry out the tasks described in step 2 or step 4 of the instructions.

Attaching the rear track (see page 27) | Attaching the front track (see page 29)

12× head cap screws M4×16 (S6) required.

Attaching the leaders (see page 55), (see page 56), (see page 57)

In the step entitled «Measure and then use a pencil to mark out a point 155 cm/61 inches to the left and the right of the marked center», use the following values: 108 cm/43 inches.



Index

A

Adjusting the handles	61
Adjusting the working height	13
Assembling the base frame	15
Assembling the machine	38
Attaching side clamps	58

B

Backing rail	
Attaching the leaders	55
Fitting	33

C

Carriage	
Alignment	35
Positioning	35
Checking the scope of delivery	12
Cross bar	
Front, attaching	21
Lower, attaching	16
Rear, attaching	18

D

Dead bar	
Attaching	53
Checking/adjusting the height	54

E

Explanation of symbols	5
------------------------	---

F

Fitting rail covers	49
Front track	
attaching	29

H

Handles	
Adjusting	60
Attaching	60
Height adjustment	13

L

Levelling feet attachment	16
Levelling the quilting frame	26

M

Machine	
Attaching V-wheel units	41
Positioning on the carriage	46
Safety brackets	47
Stand profile, attaching at the front	42
Stand profile, rear attaching	44

O

Overview of the quilting frame	6
--------------------------------	---

P

Park position magnet	36
Preparing the machine	
For assembly	41

Q

Quilting frame	
Dimensions	63
Disposal	62
Overview	6

R

Rail supports	
Adapting for Q 20	24
Attachment	23
Rear track	
attaching	27

S

Safety brackets	47
Specifications	63
Stand profile	
Front, attaching	42
Rear, attaching	44
Storage tray	59

T

Tabletops	
Attaching brackets	25
Positioning	25
Take-up rail	
Attaching	50
Attaching handwheel	52
Attaching the leaders	56
Top rail	
Attaching	32
Attaching the leaders	57

U

Unpacking the delivery	12
------------------------	----

